



## Microfluidic Dispenser

With precise flow sensor control

LFD1000 series

This microfluidic dispenser is composed of a miniaturized pump that is controlled with a proprietary thermal time-of-flight fluidic flow sensor. The product has a resolution up to 20  $\mu\text{L}/\text{min}$  with a turn-down better than 10:1. It can be applicable for both liquid and gas.

### Features

- ⦿ General purpose fluid dispensing
- ⦿ Precisely controlled with microfluidic flow sensor
- ⦿ Resolution better than 20  $\mu\text{L}/\text{min}$
- ⦿ Dynamic ranges over 10:1
- ⦿ Optional mechanical and electrical interfaces
- ⦿ Long pump lifetime

### Applications

- \* General purpose microfluidic dispensing
- \* Drug delivery
- \* Pharmaceutical process control
- \* Instrumentation
- \* Laboratory & research
- \* Automation

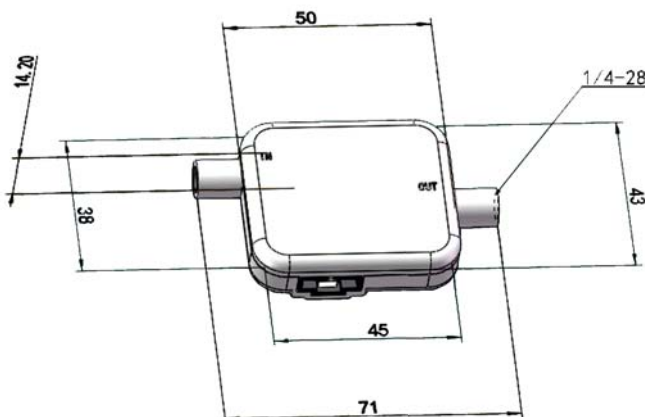

### Siargo Ltd.

Santa Clara, California  
[www.Siargo.com](http://www.Siargo.com)  
 408.969.0368  
[info@Siargo.com](mailto:info@Siargo.com)



## Specifications

	Value	Unit
Dispensing Range		
- Liquid	0.5 ~ 6.5	mL/min
- Gas	2.0 ~ 20.0	mL/min
Resolution <sup>1</sup>	± 0.05	mL/min
Accuracy	±3% or ±0.05mL/min, which ever is greater	
Pressure rating	2.0	bar
Back pressure	0.6 (liquid); 0.1(gas)	bar
Temperature rating	0 ~ 60	°C
Humidity (for gas)	0~90%RH and no icing or condensation	
Power supply	5 (±10%)	Vdc
Warming up time	200	msec
Settle time <sup>2</sup>	<20 (liquid); <5 (gas)	sec
Interface for control	I <sup>2</sup> C	
Mechanical connection	1/4" - 28 (liquid); NPT or customized (gas)	
Wetted materials	Polyphenylsulfone, PEEK, SiNx, and stainless steel or aluminum alloy	
Reference conditions	20°C, 1013 mbar; DI water (liquid) or air (gas)	
Storage temperature	-10 ~ +70	°C
Pump lifetime	5000	Hours
Protection	IP50	
CE/RoHS	EN61326-1; -2; -3	

1. 0.02mL/min achievable for a stable flow.

2. Settle time is dependent on the requirements of a stable flow dispensing. If an larger than the specified errors allowed, a faster dispensing can be achieved.

## Order information

The product part number is composed of the model number and suffixes indicating the full scale flow rate for dispensing, as well as the other parameters. Refer to the followings for details.

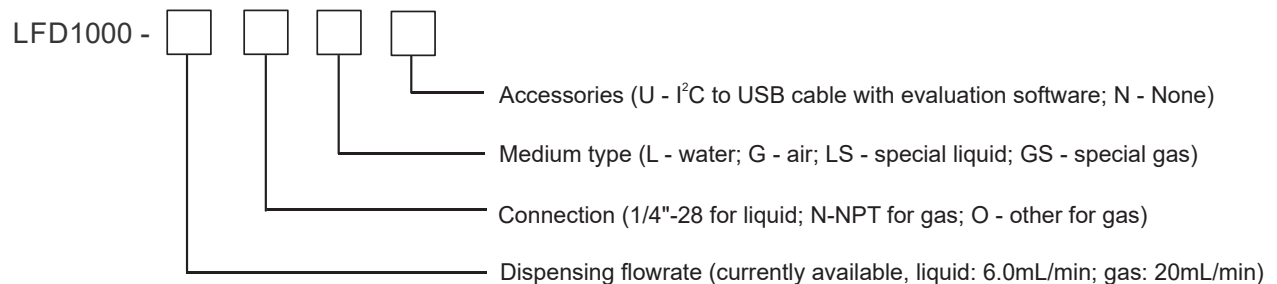

Note: for special liquid or gas other than water or air, please contact the manufacturer.

- Please find your local sales contact at [www.Siargo.com](http://www.Siargo.com).
- For detailed product information or user manual please contact manufacturer.